

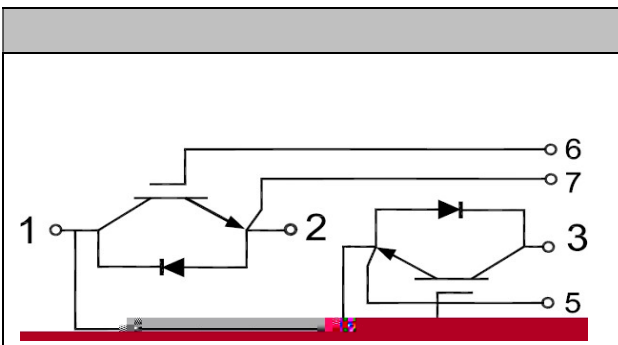

. / -- S

... --

- E f d e c b n b k a f b
- P l i f k b b
- R M P R k f k b m f i b M b P m i f b
- B i b f b i a f k d j e f k b



- E f d e n b b a f D Q f k K M Q b e k l i l d
- I l f e f k d i l b
- E f d e e l f f m f f . -
- f k i a f k d i c l c b l b k f m i i b i C T A
- I l f k a k b
- J f j j g k f k b j n b b . 2 - ° C

I i b l B j f b S l i d b	S _{BP}	S _{DB} - S) F . j) Q _g / 2 ° C	. / --	S
I k f k l I i b l b k	F	Q - ° C	... --	
O b n b f f b M b h l i b l b k	F _{OJ}	m . j	/ --	
D b B j f b S l i d b	S _{DBP}	Q _g / 2 ° C	± / -	S
Q i M b A f m f k	M _I	Q / 2 ° C Q _g . 2 - ° C	3 2	T



D b b j f b Q e b e l i a S l i d b	$S_{DB e}$	$S_{DB} S_{Bj} F_{1j} Q_g / 2^\circ C$	2-	2	3 2	S	
l i i b l B j f b l a e b k	F_{BP}	$S_B ./--S) S_{DB} -S) Q_g / 2^\circ C$. -	j	
l i i b l B j f b P f l k S l i d b	S_B	$F ./-- S_{DB} .2S) Q_g / 2^\circ C$		0-		S	
		$F ./-- S_{DB} .2S) Q_g ./2^\circ C$		0			
f k m m f k b	t	$S_B / 2S) S_{DB} -S)$		3		kC	
O b b b Q k d m f k b	b	$c . J E Q_g / 2^\circ C$		- 22		kC	
D b B j f b i b h d b b k	F_{BP}	$S_B - S) S_{DB} / -S) Q_g / 2^\circ C$			1--	k	
Q k l k A b i Q f j b	$a l k$	$F ./--$ $S_B 3-- S$ $S_{DB} .2S$ $O_{DLK} .-$ $O_{DLOC} 2.$ $Q_g / 2^\circ C$.-/		k	
O f b Q f j b				6		k	
Q k l a A b i Q f j b	$a l a$			/ 1		k	
C i i Q f j b	c			/ 1		k	
B k b d A f f m f l k A f k d Q k l k Q f j b	$B l k$.. /		j G	
B k b d A f f m f l k A f k d Q k l a Q f j b	$B l a$			/ 3		j G	
Q k l k A b i Q f j b	$a l k$		$F ./--$ $S_B 3-- S$ $S_{DB} .2S$ $O_{DLK} .-$ $O_{DLOC} 2.$ $Q_g ./2^\circ C$..-		k
O f b Q f j b					2		k
Q k l a A b i Q f j b	$a l a$				0/2		k
C i i Q f j b	c				/		k
B k b d A f f m f l k A f k d Q k l k Q f j b	$B l k$. 23		j G	
B k b d A f f m f l k A f k d Q k l a Q f j b	$B l a$			0		j G	
P A	F	$Q_m ./-- S_{DB} .2S) Q_g ./2^\circ C)$ $S 3--S) S_{BJ} ./--S$			--		



Obnrb ff b Mb hOb b bSli db	S _{00j}	Q _g / 2°C	. / --	S
l k f k l A Q a bk	F _c		. --	
Obnrb ff b Mb hQ a bk	F _{00j}	m . j	/ --	

Q aSli db	S _c	F _c . --) Q _g / 2°C		. 6	S
		F _c . --) Q _g . / 2°C		/ -	
Ob l b ba e db	N	F _c . --		23	
Mb hOb b bOb l b bk	F	S _o 3--S af _c a . / -- ,			
Ob b bOb l b Bkb d	B _b	Q _g / 2°C		0 /	j G
Ob l b ba e db	N	F _c . --		. / .	
Mb hOb b bOb l b bk	F	S _o 3--S af _c a . / -- ,		62	
Ob b bOb l b Bkb d	B _b	Q _g . / 2°C		3	j G



Fli f k li db	S _{fli}	. j f k)c 2-E	/2--			S
J fj j Gk f k Qbj nb b	Q _g				.2-	°C
L nb fkd Gk f k Qbj nb b	Q _{gl m}		1-		. /2	°C
Pl db Qbj nb b	Q _d		1-		. /2	°C
Qeb j i Ob f k b Gk f k l b	O _{e G}	nb fD Q			- . 2	H,T
		nb Af ab			- 3/-	
Qeb j i Ob f k b b l Pkh	O _{e P}	l ka f b d b b m r f a		- -2		H,T
Jl a ib Bib l ab Q n b	J	Ob l j j bkaba J2	/ 2		2-	K j
Jl a ib l Pkh Q n b	J	Ob l j j bkaba J3	0-		2-	K j
T b f d e l c Jl a ib	D			.2-		d



